

REVISIONS			
REV.	DESCRIPTION	DATE	APPROVED
A	Release for Reference	2-9-05	D.E.Dell'Ara

MODULES AND POLE SHOWN FOR ILLUSTRATION ONLY
-CUSTOMER SUPPLIED-

ITEM NO.	QTY.	PART NO.	DESCRIPTION
2	2	51-3517-242	Bucket, 35.6" SOP
3	2	51-3517-243	Clip, Left End.
4	2	51-3517-244	Clip, Right End.
5	2	51-0580-011	Rail, 70" UNI SOP
6	2	51-3029-000	Rail, 29" Inner.
7	2	51-3029-001	Rail, 29" Outer.
9	4	27-5000-010	Clamp, Hose 1.875" - 5.00"
10	2	29-5005-000	Kit, 5/16 x 3/4 (4) Set SS
	8	25-3102-000	Washer, flat 5/16" SS.
	4	23-3118-021	Bolt, 5/16-18 x 3/4 Hex CS SS.
	4	25-3101-000	Washer, lock 5/16 med split SS
	4	24-3118-440	Nut, 5/16-18 Fin Hex SS
11	2	29-5006-001	Kit, 5/16 x 3/4 (6) Set SS
	12	25-3102-000	Washer, flat 5/16" SS.
	6	23-3118-021	Bolt, 5/16-18 x 3/4 Hex CS SS.
	6	25-3101-000	Washer, lock 5/16 med split SS
	6	24-3118-440	Nut, 5/16-18 Fin Hex SS
12	2	29-5000-000	Kit, Std Mod 1/4 x 3/4 (4) Set
	4	23-2520-050	Bolt, 1/4-20 x 3/4 Hex CS SS
	4	25-2502-000	Washer, flat 1/4" SS.
	4	25-2501-000	Washer, lock 1/4" med split SS
	4	24-2520-440	Nut, 1/4-20 Fin Hex SS

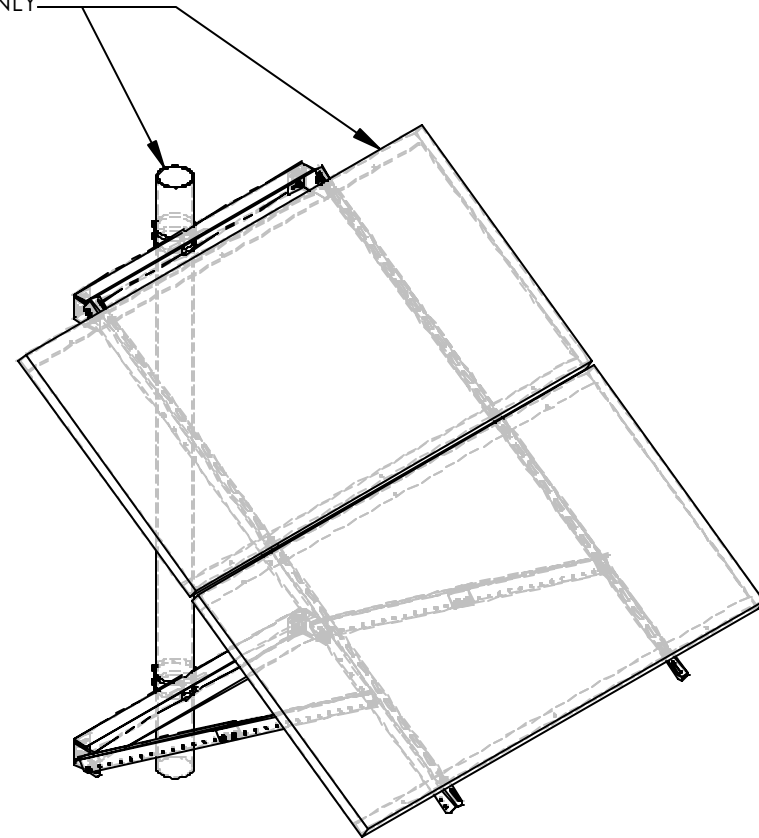

NOTES:

- 1) THE NUMBER OF MODULE KITS (ITEM 12) WILL BE DETERMINED BY THE NUMBER OF MODULES THE MOUNT IS CONFIGURED FOR.
- 2) THE BUCKETS (ITEM 2) AND RAILS (ITEMS 5/6/7) MAY VARY ACCORDING TO APPLICATION.
- 3) A SPARES KIT (TWO SEAS PART # 29-5002-100) IS SHIPPED WITH ALL LARGE SOP MOUNTING STRUCTURES.
- 4) SEE SHEET 2 FOR ASSEMBLY DETAILS.



296 Labrosse Ave., Pointe-Claire, QC, H9R 5L8
Toll Free 1 866 630-5630 www.matrixenergy.ca

REVISIONS			
REV.	DESCRIPTION	DATE	APPROVED
A	Release for Reference	2-9-05	D.E.Dell'Ara

HOSE CLAMPS

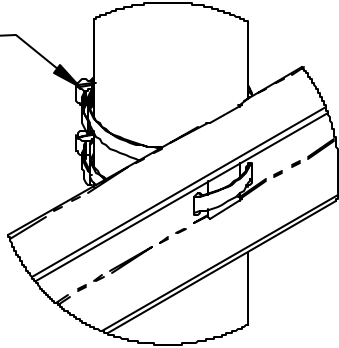

DETAIL A
SCALE 1 : 5

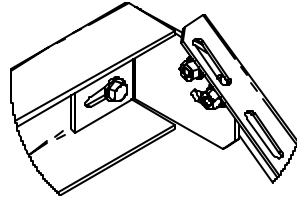

DETAIL B
SCALE 1 : 5

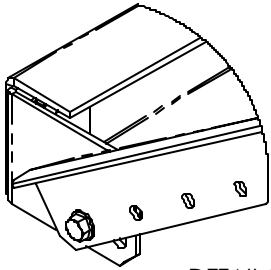

DETAIL E
SCALE 1 : 4

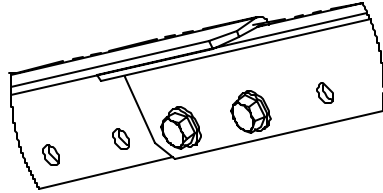

DETAIL C
SCALE 1 : 3

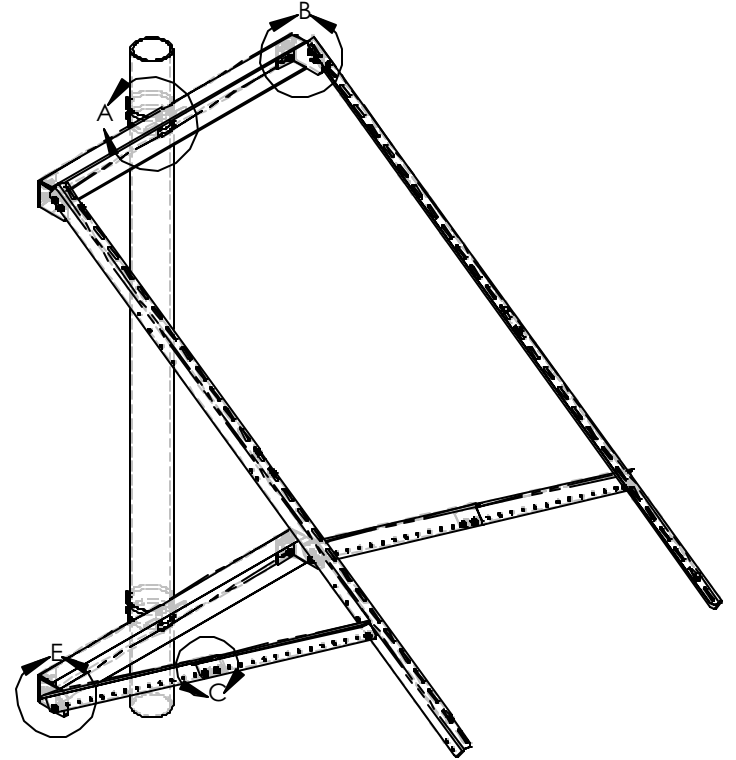

OPTIONAL U-BOLT INSTALLATION (NOT SUPPLIED)
USES CUSTOMER SUPPLIED U-BOLT. ENSURE THAT
OVERSIZE OD WASHERS ARE USED TO EVENLY SPREAD
CLAMPING LOAD, DO NOT OVER TORQUE THE
U-BOLT AS BUCKET FAILURE MAY RESULT.

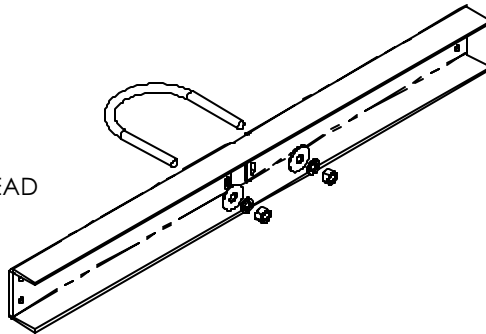

É N E R G I E
MATRIX
E N E R G Y

296 Labrosse Ave., Pointe-Claire, QC, H9R 5L8
Toll Free 1 866 630-5630 www.matrixenergy.ca