

## Application Note

# Grid Connection Options and Configuration for Aurora String Inverters

Revision: 001  
Revised: 10OCT2010

[TABLE OF CONTENTS](#)

**Aurora Grid Connection Options**

- 1. Introduction .....3
  - 1.1. Scope ..... 3
- 2. Aurora Grid Connections .....3
  - 2.1. Electrical Wiring for Three Phase Aurora Inverters ..... 3
  - 2.2. Electrical Wiring for Single Phase Aurora Inverters ..... 3
  - 2.3. Making Changes to the Inverter Configuration ..... 5
    - 2.3.1. Navigating the Inverter Configuration.....5
    - 2.3.2. Setting the Grid Type ..... 6
    - 2.3.3. Setting the Grid Nominal Voltage ..... 6
- 3. North America Grid Standards.....8

**REVISION TABLE**

Document Revision	Author	Date	Approved by	Description of Modification
001	R. Allen	10OCT2010		Original Release

## 1. Introduction

Power-One's Aurora String Inverters are designed to feed energy harvested from PV and wind sources to a local utility distribution system (aka, the grid). However there are several available types of grid connections depending upon the intended usage of the installed electrical service. Aurora Inverters are designed to be connectable with any of the utility low voltage service connections available in the world, including single phase, split phase and three phase systems.

This document provides details of how to wire the grid interconnection and procedures needed to adjust the inverter operating system (configuration) to match the desired grid connections. The appendix lists various NA grid standards and connections.

### 1.1. Scope

This document is applicable to the all Aurora PVI Wind and Photovoltaic (PV) series string inverters, including both transformerless and isolated versions.

**NOTE:** If Aurora transformerless Inverters are used in parallel or in three-phase applications and are fed by a common source such as a single wind turbine, isolation transformers will need to be incorporated in the grid connection. Please refer to Aurora application note entitled, **Aurora TL Wind Inverters and Parallel Usage**, for details.

The following sections provide descriptions of how Aurora String Inverters must be electrical-phase.

For all models the appropriate grid wiring connections are provided on a label affixed to the unit. The information in Figure 2-3 is an expanded version of this label and shows all possible grid wiring options.

ly connected, and procedures for changing the inverter configuration to match the various grid standards. The Appendix includes detailed information on the various NA grid standards.

## 2. Aurora Grid Connections

### 2.1. Three-Phase Aurora Inverters

The three phase PVI-series string inverters designed for the NA market for either wind or PV applications have preset grid voltages of either 208V or 480V 3 $\phi$  connections and do not need configuration changes to allow connection to these grid standards.

### 2.2. Single-Phase Aurora Inverters

Connection of a single phase Aurora Inverter to the grid requires connecting either two or three conductors depending upon the grid type. The specific location of the 3-terminal grid wiring block depends upon whether the inverter is provisioned with a DC switchbox. There are no switches associated with the grid-side wiring; however, addition of the optional switchbox changes the location of the AC grid terminal block. See Figure 2-1 and

Figure 2-2 for differences in these two implementations.

As shown in these figures, the AC grid connection for any single-phase Aurora inverter consists of a terminal block with three positions. The number of positions used (either two or three) is dependent upon whether the grid to be connected is single phase or split

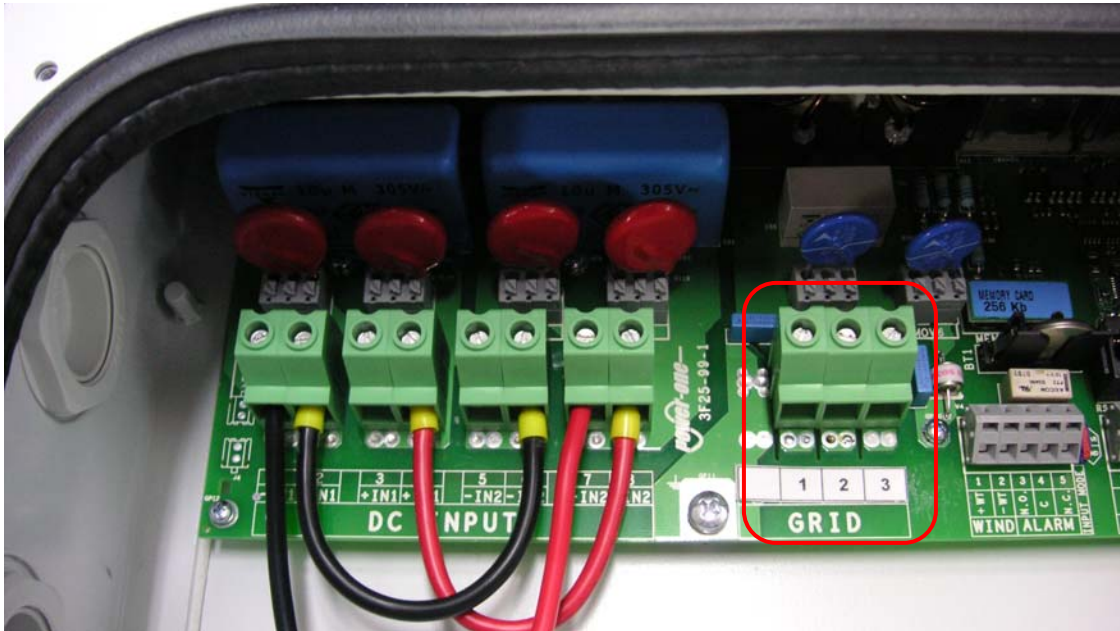

Figure 2-1: Grid wiring terminal block for single-phase Aurora inverters without a DC switchbox

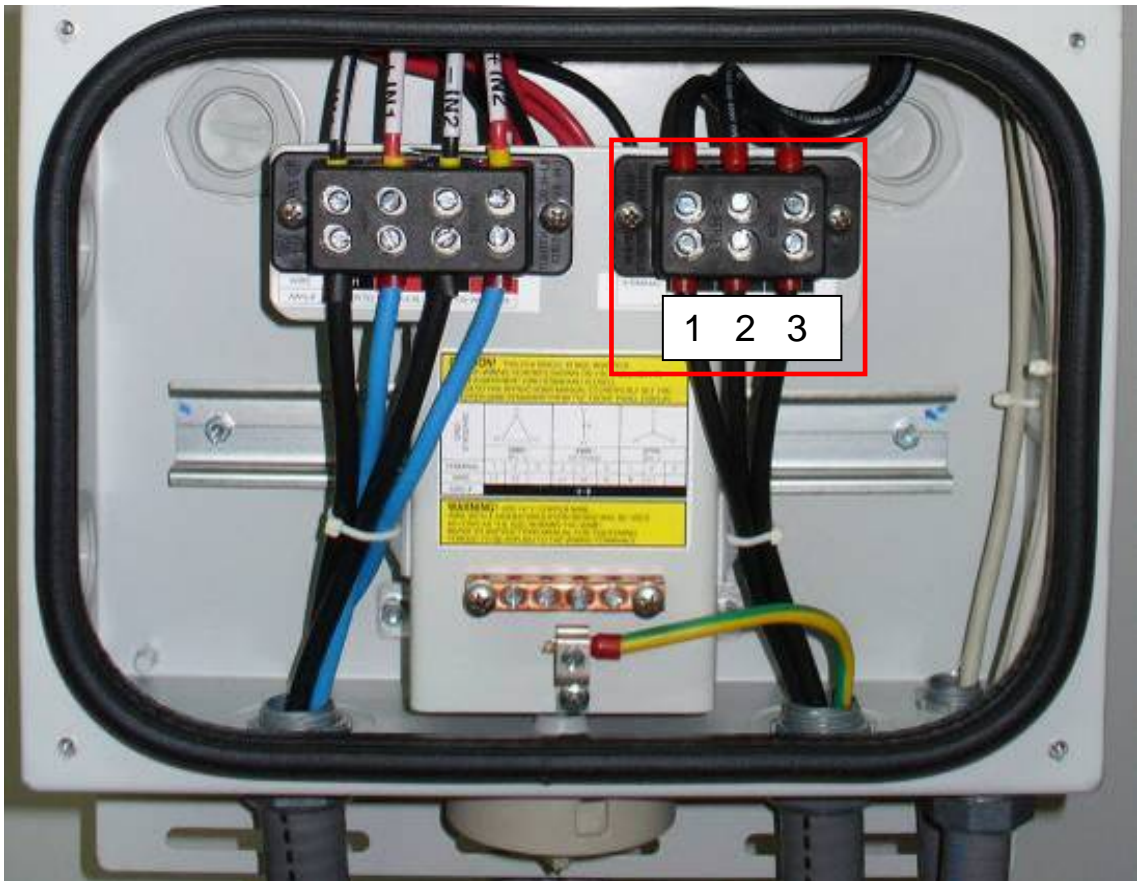

Figure 2-2: Grid wiring terminal block for single-phase Aurora inverters with optional switchbox provisioned



GRID STANDARD									
	208V~ 3PH - Δ			240V~ SPLIT-PHASE			277V~ 3PH - Y		
Inverter TERMINAL	1	2	3	1	2	3	1	2	3
Wiring Option A	L1	L2	-	L1	L2	N	N	L1	-
Wiring Option B	L2	L3	-	-	-	-	N	L2	-
Wiring Option C	L3	L1	-	-	-	-	N	L3	-

Figure 2-3: Grid Wiring Information for all single-Ø inverters showing all wiring options

### 2.3. Making Changes to the Inverter Configuration

Based on the grid standard to which inverter must be connected, the Aurora inverter may need to have changes made to its configuration data. The correct grid type and nominal grid voltage must be programmed correctly into the configuration file to allow proper and safe operation of the inverter. This is easily accomplished using the front panel key pad adjacent to the front panel display.

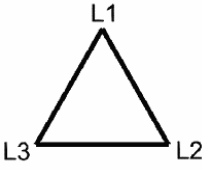
The default configuration setting for all US models is 240V/120V split-phase, and if connecting to this grid configuration, no adjustments are required. To select a different grid standard and/or nominal grid voltage different from this default, refer to the following procedures.

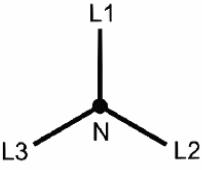
#### 2.3.1. Navigating the Inverter Configuration

Both of the following procedures require the user to enter multiple digit values (e.g., 4-digit passwords, 3-digit voltages) into the inverter control system. This is accomplished using the display and the front panel arrow keys. In the procedures below, after entering a location where numerical value entry is required use the front panel arrow keys to navigate digit positions on the display and change digit values:

- Use the up/down [↑↓] front panel arrow keys to change the value of a digit as required.
- Use the right/left [← →] arrow keys to move the cursor from one digit position to the next (left or right)
- Repeat this process to enter values in all digit positions as required

## Aurora Grid Connection Options

### 2.3.2. Setting the Grid Type

The Grid Type for Aurora single-phase inverters can be either single phase or split phase. To adjust the grid type of the inverter:

1. Power-on the inverter by applying 200VDC to one set of DC input terminals. This can be done prior to installation of the unit using a DC power supply capable of supplying the required voltage, or it can be completed once the inverter has been installed and connected to the PV array, but prior to connection to the grid. In either case, hazardous voltages can be accessible so exercise extreme caution
2. Press the **ESC** key to access the submenu directory
3. Using the arrow keys as necessary, move the cursor to highlight the **SETTING** menu, and press the **ENTER** button
4. At the prompt, type in the basic password [0000] (using the procedure of Section 0) to access the **SETTING** submenu
5. Use the up/down [↑↓] arrow keys move the display cursor to highlight the **SELECT GRID STANDARD** menu item and press the **ENTER** button.
6. Use the up/down [↑↓] arrow keys to move the cursor to the desired choice of grid type (Single or Split phase)
7. When complete, press the ESC button several times to return to the main menu, or alternatively power cycle the unit.

### 2.3.3. Setting the Grid Nominal Voltage

Prior to commencing this procedure, the **second level (service) password** for the inverter must be obtained by request from the Power-One Technical Center. This password is specific to each inverter and is based on the unit serial number.

As access to this menu also allows access to other controlled parameters, which if modified without consent and approval by Power-One can result in unsafe operation and/or damage to the inverter. Therefore, before the second level password can be released it is necessary to ratify the limited liability form found in section 4 of this document. Once this password is obtained, proceed as follows:

1. Open inverter access cover and apply 200VDC to one set of DC input terminals. This can be done prior to installation of the inverter using a DC power supply capable of supplying the required voltage. Alternatively, this can be accomplished once the inverter has been installed and connected to the PV array; however, **it must be completed prior to connection to the grid.** In either case, use extreme caution as hazardous voltages can be easily accessible!
2. Once powered, press the **ESC** key to access the main system menu
3. Using the up/down [↑↓] arrow keys as necessary, move the cursor to highlight the **SETTING** menu item, and press the **ENTER** button
4. At the prompt, enter the first level user password, always [0000] using the procedure of Section 0. When complete, press the **ENTER** button to access the **SETTINGS** submenu.

---

**Aurora Grid Connection Options**

5. From the **SETTINGS** menu, using the up/down [↑↓] arrow keys move the cursor to highlight the **SERVICE** submenu and press the **ENTER** button.
6. At the prompt, enter the second level service password previously obtained in Step (1). Use the procedure of Section 0 to enter the values. When completed, press the **ENTER** button to enter the **SERVICE** menu.
7. From the **SERVICE** menu using the up/down [↑↓] arrow keys move the cursor to highlight the **V NOM** menu item, and press the **ENTER** button.
8. Using the arrow keys navigate the cursor (per the procedure of 0) to enter the desired 3-digit nominal grid voltage; when complete, press the **ENTER** button.
9. When complete, press the **ESC** button several times to return to the main menu, or alternatively power cycle the unit.

Aurora Grid Connection Options

### 3. Appendix A: North America Grid Standards

Historically, there have been a number of different NA utility grid standards, which for the most part have evolved into those listed in Table 3-1, and which are the primary standards in use today. If the user encounters any connec-

tions different from those listed, contact the Power-One Technical Center for further instructions.

With regard to line frequency In North America, all utility AC transmission and distribution operates at a frequency of 60Hz.

Table 3-1: Popular NA Grid Standards					
Voltage <sup>1</sup>	N <sup>o</sup> Phases	Phase Type	N <sup>o</sup> of Conductors	Reference	Application
240/120	1	Split	3	Figure 3-3	Single phase residential
208/120	3	Wye	4	Figure 3-1	Three phase -Light Commercial (default standard)
240/120	3	High leg	4	Figure 3-2	Three-phase -Light Commercial (limited usage)
480/277	3	Wye	4	Figure 3-1	Heavy Commercial/industrial
600/347	3	Wye	4	Figure 3-1	Heavy Commercial/industrial (Canada)

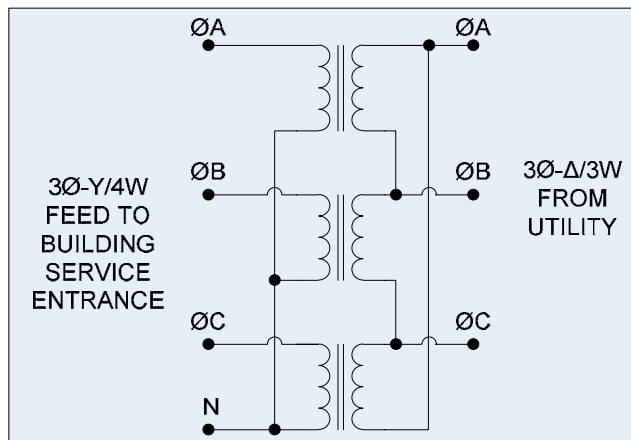

Figure 3-1: 3Ø-Y/4W service entrance used to provide 208V/120V/3Ø-Y or 480V/277V/3Ø-Y facility service entrances.

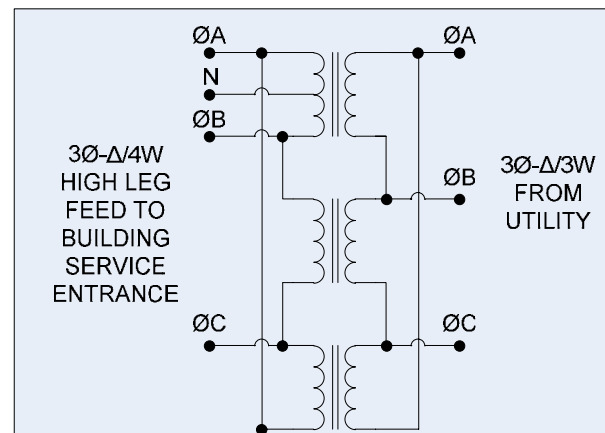

Figure 3-2: 3Ø-Δ/4W (HIGH LEG) service entrance used to provide both 240V/3Ø-Δ and limited 120/1Ø facility service entrance.

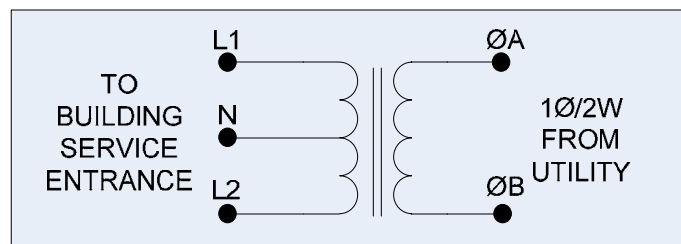

Figure 3-3: 1Ø/3W service entrance used to provide 240V and 120V/1Ø service for residences.

<sup>1</sup> V1 / V2 – V1 indicates system phase to phase voltage; V2 indicates system phase to neutral



#### 4. CONDITIONAL ACCESS AGREEMENT

##### Access Agreement to allow access to the restricted “Advanced Menu” of Aurora Wind and Photovoltaic Inverters via Aurora Installer software

In the following Agreement the word “CUSTOMER” is intended to refer to the undersigned party in the CUSTOMER COMPANY NAME area at the bottom of this document

Power-One is delivering to the **CUSTOMER**, a password(s) to allow access to the restricted **Advanced Menu** area within the **Aurora Installer** software.

Hereby Power-One states that the **Advanced Menu** is a restricted area within the **Aurora Installer** software that allows access to parameters, which if modified improperly can have an impact on the product certification and operation.

**As such, any changes made without explicit written permission from Power-One will void any safety certifications as well as the Power-One warranty.**

In signing this document **CUSTOMER** accepts the restrictions and acquires full responsibility for any issue(s) that arises as a result of changes made to any parameters within the **Advanced Menu**, where not previously agreed upon and documented with Power-One, Inc.

This document is executed expressly to allow the following changes to **Advanced Menu** parameters:

1. Modifying the nominal grid voltage setting from the 240V default to match necessary grid level
2. Setting must be within specified datasheet limits for grid voltage

Power-One, Inc	Customer Company Name	_____
Renewable Energy BU	Business unit	_____
740 Calle Plano Camarillo, CA 93012	Customer address	_____
_____	Signature	_____
_____	Printed Name	_____
_____	Date Signed:	_____